

# FS1-178 & FS1-203 Valves

Solenoid Powered to Close / Manual Reset Butterfly Valves

*Part of the F Series of easily installed, compact, air intake valves for diesel engine emergency shut down.*



wyndham|page

## About Wyndham Page Ltd

Based in the UK Wyndham Page specialise in the design and manufacture of safety equipment for diesel engines.

Our product range of Air Intake Shutdown Valves includes our E Series Automatic Valves and our F Series Butterfly Valves with solenoid, pneumatic or manual actuation options. We offer Speedswitch kits for the F Series valves, a range of G Series Mechanical Engine Safety Products and a range of Spark Arresters designed to prevent the emission of high energy sparks from diesel exhaust systems.

Wyndham Page is headed by Freddy Page-Roberts who brings over 20 years' experience in the diesel safety industry and was previously managing director of Chalwyn Ltd.

All members of the senior management team have considerable experience in organisations specialising in the design and manufacture of hazardous area equipment for diesel engines.

## Quality Assurance

Wyndham Page Valves are manufactured and tested under our EN ISO 9001: 2015 quality management system.

Wyndham Page Ltd are certified to supply Ex equipment under Quality Assurance Notification CML ATEXQ11003 in the UK, CML ATEXQ13649 in the EU and IECEx Quality Assurance Report GB/CML/QAR17.0023/01.

- Ex Equipment supplied with an UK Declaration/Assertion of Conformity is CA marked and meets the provision of the UK directive SI 2016No. 1107
- Ex Equipment supplied with an EU Declaration/Assertion of Conformity is CE marked and meets the provision of the ATEX directive 2014/34/EU
- Other Equipment supplied with an UK Declaration/Assertion of Conformity or an EU Declaration/Assertion of Conformity is CA / CE marked and meets the provision of the directives specified in the Declaration of conformity.

## FS1 Valves: Application

The FS1-178/203 valves are designed for diesel engine applications where the bore of the air intake pipe is 178mm (7 inches) or 203mm (8 inches). For FS1 valves suitable for smaller bore air intake pipes see handbook FS1 Valves: 38mm to 171mm.

The FS1 version of the Wyndham Page F Series of engine air intake shutoff valves is designed to provide an emergency means for rapid shutdown of a diesel engine when triggered by a 12V or 24V DC signal. This signal may be generated automatically by engine overspeed or any other selected fault condition or via a manually operated electrical engine stop button. The valve is supplied as standard with a mechanical stop button mounted on the valve. As well as providing an additional emergency stop (if accessible) this can also be used during installation and testing to close the valve without an electrical signal. This feature can optionally be supplied remotely mounted for operation via a mechanical push cable.

Once the FS1 valve has operated to stop the engine, a restart is only possible after manually resetting the valve to the run position. The low intake air flow restriction through the open valve makes it generally compatible with the requirements of low emission diesel engines.

Corrosion resistant materials are used where applicable in the construction of the valve. This lightweight and compact valve design together with the availability of factory fitted hose adaptors selected from a wide range of optional sizes assists in easy installation.

The valve may be fitted to either turbocharged or naturally aspirated engines. In the case of turbocharged engines temperature limitations may restrict the position in which the valve may be installed in the intake system.

**Note.** Wyndham Page also supply speedswitch kits for incorporation into the emergency shut down control circuit of this type of application. Please contact Wyndham Page or your Wyndham Page supplier for details.

# Description and Main Dimensions

The FS1 butterfly valve is a latched open type. Either operation of the manual engine shutdown button or applying a 12V or 24V DC signal is required to trip the valve to the closed [engine stop] position. Following valve closure the manual reset lever on the valve is used to reset to the latched open position. Optionally the valve can be supplied with a cable and lever arrangement to permit manual reset from a position remote from the engine.

In standard form FS1-178/203 valves are supplied complete with hose adaptors – see diagram below and on page 5. Where a requirement exists for a non-standard adaptor size or other alternative form of pipe connection such as a flanged joint please pass details of requirement to Wyndham Page or your Wyndham Page supplier for investigation.

Optionally the valve can be supplied fitted with an internal microswitch to indicate the open/closed status of the valve.

The valve has a metal to metal seal when closed. It is designed for low closing friction and long life of the sealing surfaces. The latching / release mechanism is configured to withstand high shock loads without malfunction.

The electrical enclosure is to IP66.

The diagram below and the diagrams and data on pages 5 to 6 cover the main features and basic dimensions of the FS1-178/203 valves including selection of options and order coding.

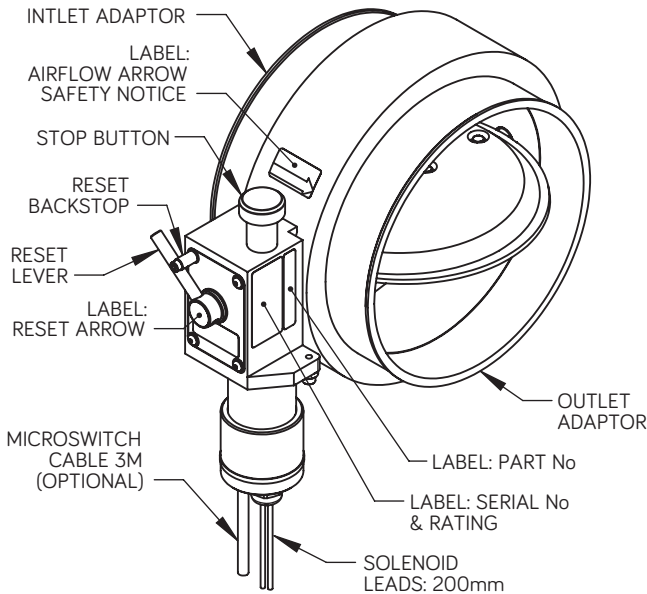

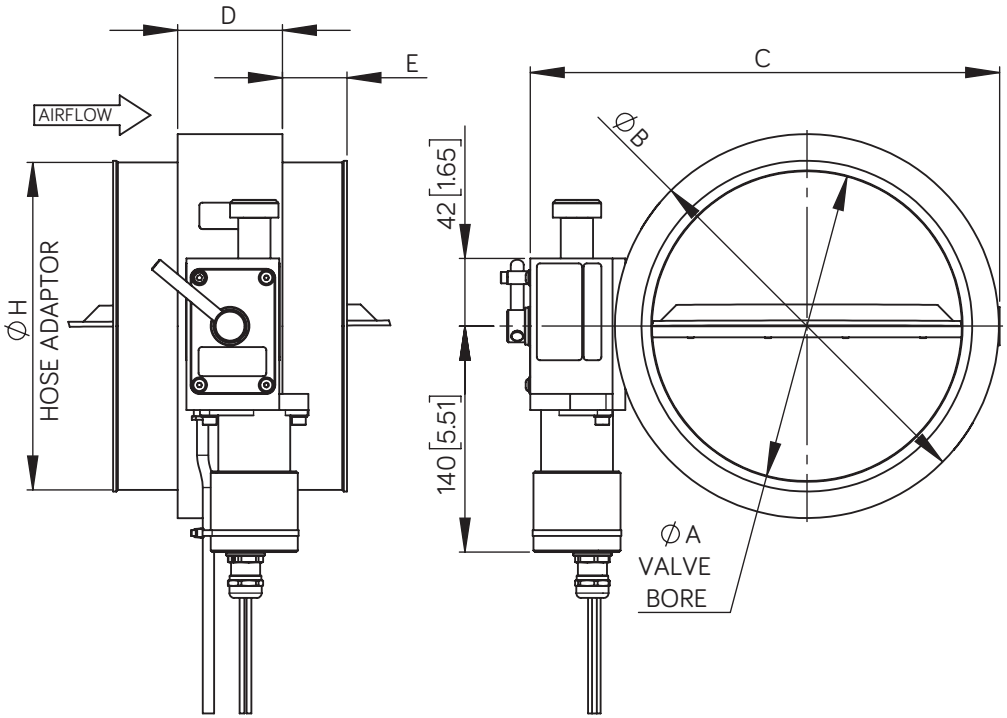

METRIC TABLE		DIMENSIONS (MM)					WEIGHT KG	ORDER CODE
MODEL	H TO SUIT HOSE BORE	BORE A	B	C	D	E		
FS1	178	171	215	270	56	30	4.6	178
	203	192	238	291	65	40	6	203

IMPERIAL TABLE		DIMENSIONS (INCHES)					WEIGHT LB	ORDER CODE
MODEL	H TO SUIT HOSE BORE	BORE A	B	C	D	E		
FS1	7.01	6.73	8.46	10.63	2.2	1.18	10.14	178
	7.99	7.56	9.37	11.46	2.56	1.57	13.23	203

# Valve Selection

To enable Wyndham Page to select the most suitable version of the FS1 valve for the Customers application the following data is required:

- [1]. Bore size of the intake hose into which the intake valve is to be fitted - refer to section headed "Description and Main Dimensions".
- [2]. Whether a 12V or 24V DC shutdown signal is to be used.

**The following additional options are available**

- [3]. A built in microswitch (see page 10)
- [4]. A remote mechanical emergency stop (see page 11).
- [5]. A reset cable (see page 11).

# Order Coding

**FS1 - XXX - XX - M - RXX - EXX - S000**

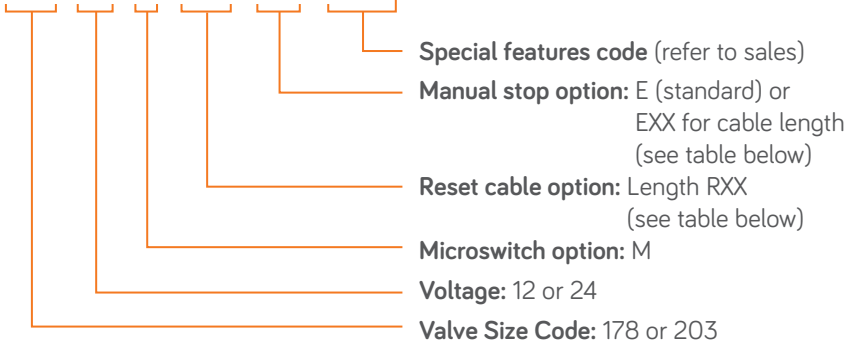

STANDARD CABLE LENGTHS	
CABLE XX CODE	LENGTH (M)
05	0.5
10	1.0
15	1.5
20	2.0
25	2.5
30	3.0

**Special Features:**  
By arrangement with Wyndham Page.

# Valve Installation [mechanical]

Select a position for the valve which meets the requirements below. The valve may be fitted in any attitude from horizontal to vertical but not in a position where it is subjected to temperatures, internal or external, outside of the range  $-40^{\circ}\text{C}$  to  $+120^{\circ}\text{C}$ . When planning and checking installation always ensure that:

- a. There is safe access to operate the mechanical stop button and a suitable run for the connected electrical cables and manual start cable if fitted.
- b. The direction of airflow is in compliance with the arrow marked on the body of the valve.
- c. An **Air Filter Element** must always be fitted in the engine air intake system **upstream** of the Valve.
- d. Valve location in the Air Intake System (refer to schematics below):

Yes ✓ No ✗

In all cases the Valve must be located where both ambient and intake air temperature does not exceed  $120^{\circ}\text{C}$ .

- **Normally Aspirated Engines (no turbocharger):** fit the valve between the engine and the air filter (see schematic below).

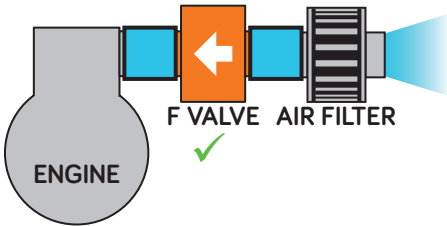

- **Turbocharged Engines:** fit the valve upstream [air filter side] of the turbocharger. **Do not** fit the valve between turbocharger and engine (see schematic below).

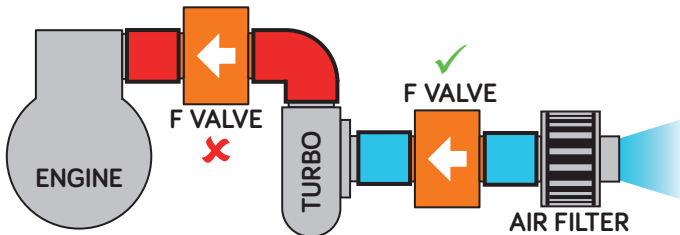

- **Turbocharged Engines with Intercooler:** fit the valve upstream (air filter side) of the turbocharger or downstream of the intercooler. **Do not** fit the valve between turbocharger and intercooler (see schematic below).

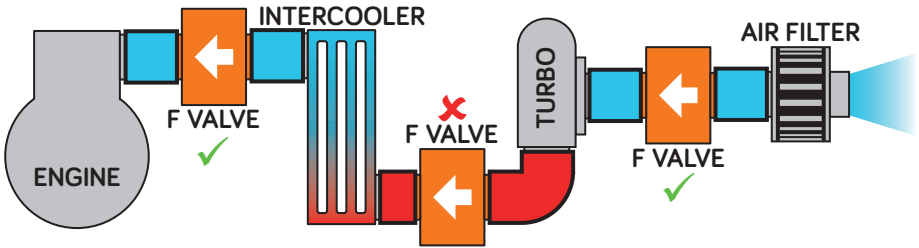

- In all cases where an **Intake Flametrap** is also fitted, the valve must be installed **upstream** of the flametrap.
- The hose into which the valve is fitted should be adequate to fully support the valve whilst not permitting excessive vibration of the valve. For the heavier valves in the range a support bracket for the valve may be necessary. Generally ensure that there is sufficient flexibility in the finalised intake system installation to allow for the relative movement between the system components over the full range of engine operating conditions thereby avoiding excessive mechanical stresses.
- Any engine **Crankcase Breather** arrangement venting directly into the intake ports or into the air intake system downstream of the Wyndham Page valve must be sealed and replaced by an external breather system connected to the intake system upstream of the valve or [if permitted at the operating site] vented to atmosphere.
- When installing valves fitted with the manual cable option RXX ensure that the bend radius of the Cable does not restrict the mechanism from pulling the T Handle back into the run position. If it is found that the T Handle is not being pulled fully in then a straighter run for the reset cable must be used.

**Important Note.** Retain the standard fuel shutdown stop fitted to the engine. The Wyndham Page FS1 air intake valve is designed for emergency stop only.



## Valve Installation [electrical]

The wiring diagram overleaf shows the connections for the valve solenoid and optional microswitch.

The electrical data for the solenoid and microswitch is tabulated on page 12.

It is recommended that either a manually operated electrical engine stop button or a remotely operated mechanical engine stop button is always incorporated.

The solenoid power supply cable must be adequately secured along its length to avoid excessive mechanical stress at the connection to the solenoid or any other physical damage under all normal operating conditions and during equipment servicing.

### Important notes.

1. The electrical system must include means to restrict the maximum time the stop signal may be applied to the solenoid to within the limits stated on page 12. This restriction must also be applied where a manually operated electrical engine stop button is also incorporated in the electrical shutdown circuit.
2. The solenoid draws a high current (46A or 25A) and must be switched through a suitable relay. We recommend the use of the Wyndham page TTu-04 solenoid driver, this is suitable for both 12V and 24V valves and will also limit the time the coil is energised as specified above.
3. It is recommended that for additional safety when a manually operated electrical engine stop button is incorporated it should be directly supplied by the required voltage from source and not via the shutdown control circuit.

# Wiring Schematic & Microswitch Option

## FS1-178/203 Valve:

Internal wiring schematic

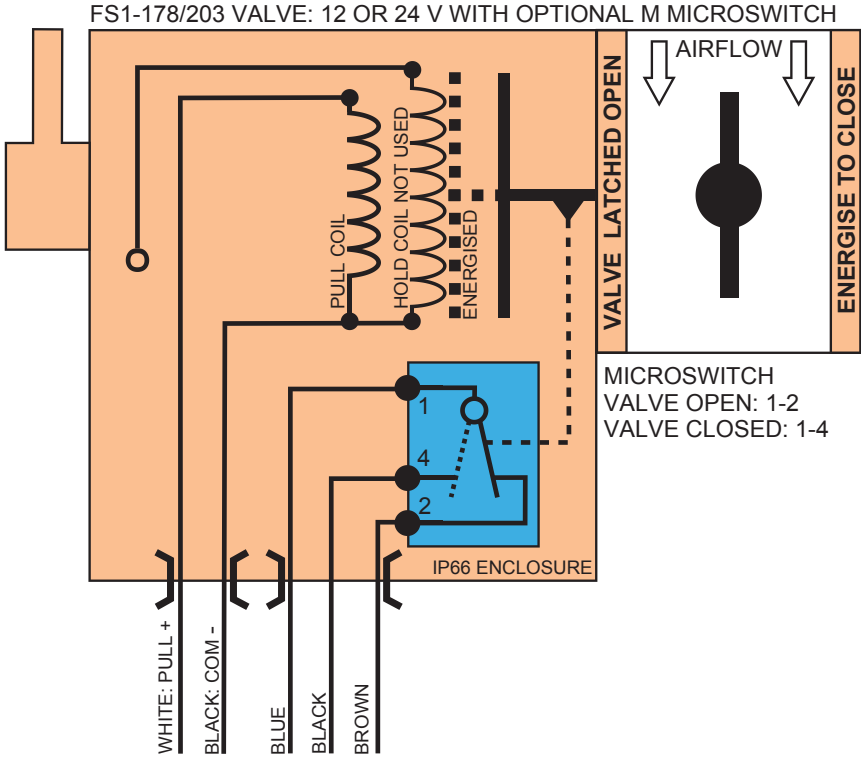

# Additional Options:

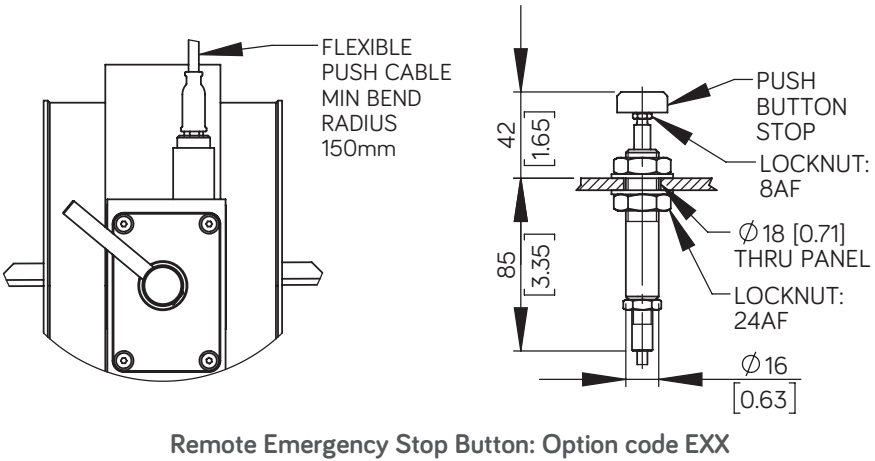
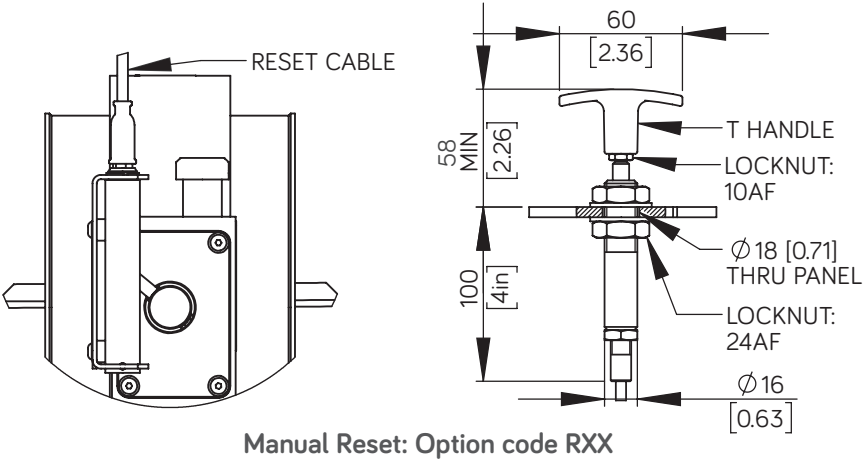

# General and Electrical Specification

<b>GENERAL DESCRIPTION:</b>	
A slim butterfly valve designed for emergency shutoff of the engine air intake.	
Mechanically latched open, energise to close, manual reset by rotation of reset lever.	
<b>GENERAL SPECIFICATION:</b>	
Temperature:	Max ambient: 120°C Max intake air temp: 120°C
Construction:	Body and disk: Hard anodized aluminium Other main components: Stainless steel, aluminium Hose adaptors: Aluminium
Weight:	See page 5
<b>ELECTRICAL SPECIFICATION:</b>	
Solenoid energise to close operation	
12 or 24 volt DC option specified when ordering	
Solenoid rating:	12 VOLT DC, 46A 24 VOLT DC, 25A
Max single pulse @20°C:	1.5 seconds
Max 4 cycles in one minute	
Recommended engine controller setting:	1 second
<b>MICROSWITCH OPTION:</b>	
S.P.D.T - 24V, 10A Max	
<b>MICROSWITCH CABLE:</b>	
SIHF silicone insulated multicore cable: Standard length 3m	

## Operation

The valve disc is sprung towards the engine stop [closed] position. It is latched in the engine run [open] position by rotating the reset lever as indicated on the valve until it contacts the backstop, or where a remote manual reset is fitted, by pulling the reset 'T' handle. During engine operation the valve remains open until a 12 or 24 volt DC shutdown signal is applied or the manual emergency stop button is operated. This releases the valve disc from the run to the stop position thereby shutting down the engine.

**Note.** Unless released to the closed position by an electrical signal or the manual emergency stop button the valve disc will remain in the latched open state and therefore following a normal engine stop by fuel shutdown a reset is not required. IT IS NOT POSSIBLE TO MANUALLY CLOSE THE VALVE USING THE RESET LEVER, ATTEMPTING TO DO SO MAY DAMAGE THE INTERNAL MECHANISM.

Where fitted the internal microswitch permits an indication of the valves open / closed status.

## Maintenance

The following maintenance schedule should be undertaken. Subject to experience of local operating conditions the frequency of the maintenance schedule may be varied. Carry out the proposed maintenance work when the equipment is in a safe area and record details of the work carried out. Rectify any problems identified before returning the diesel powered equipment back into service.

### FOLLOWING INITIAL INSTALLATION AND THEREAFTER AT WEEKLY INTERVALS:

- [1]. Check all intake pipework between the FS1 valve and engine intake manifold to ensure all pipe fittings and any support brackets are properly fitted and secure and that the engine intake is leak free and shows no sign of significant deterioration or damage.
- [2]. Inspect the power supply and microswitch cables for damage.
- [3]. Start engine. Carry out a shutdown using the stop signal from the shutdown control system. Check that the valve snaps shut and brings the engine to a stop within a few seconds.
- [4]. Repeat step [3] by operating the mechanical stop (where fitted) and again check that the valve snaps shut and brings the engine to a stop within a few seconds.

### SIX MONTHLY:

Remove the FS1 valve. Wipe clean as necessary and visually inspect for damage or excessive wear. Bench test valve function. Refit and complete the “Weekly” maintenance as listed above.

Notes:

wyndham | page

Unit 1c Chalwyn Industrial Estate, Parkstone, Poole,  
Dorset BH12 4PE United Kingdom

Tel: +44 (0)1202 734 656

Email: [sales@wyndhampage.com](mailto:sales@wyndhampage.com)

[www.wyndhampage.com](http://www.wyndhampage.com)