

E-M Series

Combined Manual and Automatic Engine Overspeed Shutdown Valves

A range of easily installed diesel engine air intake valves which automatically close on engine overspeed and also incorporate a manual shutdown feature for additional safety.

**ATEX &
UKEX
Certified**



About Wyndham Page Ltd

Based in the UK Wyndham Page specialise in the design and manufacture of safety equipment for diesel engines.

Our product range of Air Intake Shutdown Valves includes our E Series Automatic Valves and our F Series Butterfly Valves with solenoid, pneumatic or manual actuation options. We offer Speedswitch kits for the F Series valves, a range of G Series Mechanical Engine Safety Products and a range of Spark Arresters designed to prevent the emission of high energy sparks from diesel exhaust systems.

Wyndham Page is headed by Freddy Page-Roberts who brings over 20 years' experience in the diesel safety industry and was previously managing director of Chalwyn Ltd.

All members of the senior management team have considerable experience in organisations specialising in the design and manufacture of hazardous area equipment for diesel engines.

Quality Assurance

Wyndham Page Valves are manufactured and tested under our EN ISO 9001: 2015 quality management system.

Wyndham Page Ltd are certified to supply Ex equipment under Quality Assurance Notification CML ATEXQ11003 in the UK, CML ATEXQ13649 in the EU and IECEx Quality Assurance Report GB/CML/QAR17.0023/01.

- Equipment supplied with an UK Declaration of Conformity is CA marked and meets the provision of the UK directive SI 2016No. 1107
- Equipment supplied with an EU Declaration of Conformity is CE marked and meets the provision of the ATEX directive 2014/34/EU.

E-M Series Valves: Application

The E-M Series of Wyndham Page combined manual and automatic overspeed shutdown valves are designed to be fitted to the air intakes of Diesel engines operating in areas where flammable gas, vapour or dust may enter the atmosphere and are certified for use in Zone 2, gas group IIB and Zone 22, dust group IIIB hazardous areas.

Should such flammable material be drawn into the engine intake this may result in uncontrolled engine overspeed and a situation in which shutdown of the normal diesel fuel supply may fail to stop the engine.

Under these circumstances a rapid shutdown of the engine is required by immediate closure of the engine air intake thereby reducing the potential for major damage and possible ignition of the flammable material in the surrounding atmosphere.

The E-M Series of Wyndham Page automatic engine air intake shutdown valves are suitable for installation in the intakes of either naturally aspirated or turbocharged engines.

Once installed and set, the repeatability of the actual engine automatic shutdown speed has a greater scatter in the case of turbocharged engines than for naturally aspirated types. However, unless there is a special requirement for a very precise shutdown speed, adequate protection from excessive engine overspeed is achieved.

Enhanced Protection [Manual Shutdown]

The Wyndham Page E-M Series of automatic overspeed intake shutdown valves includes a manual actuator connected to the valve via a mechanical cable to enable manual emergency valve closure.

E90SM Valve

This is the largest valve in the range, basic data is contained in this handbook, for full details please refer to the separate E90S Valves Handbook.

Principle of Operation [Automatic Overspeed Shutdown]

The actuation force to close the valve is derived from the engine intake airflow passing through the valve. As the airflow increases this actuation force also increases. This force is resisted by an internal valve spring, the pre-load of which is adjusted via the "Trip Adjuster Screw".

Once the actuation force exceeds the resisting force of the valve spring, the valve rapidly moves to the closed position. Once closed the E-M valve remains shut until the engine has fully stopped. The valve then resets to the open position after a delay of some seconds.

Description & Main Dimensions

A typical E-M Series valve is shown below. The overall dimensions for this range of valves are given on page 5.

The valve is supplied complete with hose adaptors [to slide into the engine air intake hose] selected in consultation with the customer from a range typical for the rating of the engine to be protected. The standard stocked lengths from which the marine grade manual shutdown cable may be selected are given on page 6. Alternative cable lengths may be available on application.

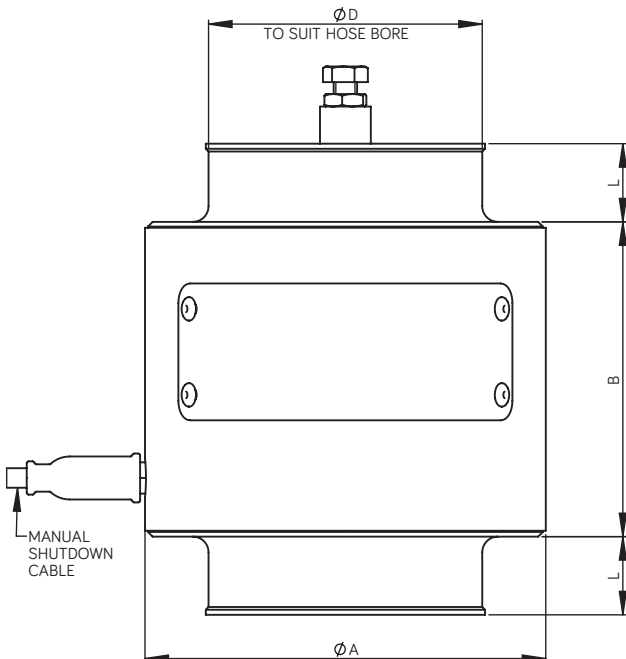

METRIC TABLE	ENGINE POWER RANGE (KW)		DIMENSIONS (MM)												
	MODEL	MIN	MAX	A	B	L (MAX)	MASS (KG)	STOCK HOSE ADAPTORS D (OTHER SIZES AVAILABLE ON REQUEST)							
E02M	3	18	66	65	20	0.34	25	35	38	41	45				
E05M	4	27	81	65	20	0.46	35	38	41	45	48	51	60		
E10M	7.5	45	102.5	80.5	20	0.69	45	48	51	55	58	60	62	64	70
E20M	30	78	121.5	83	20	0.86	45	51	60	64	70	77			
E30SM	40	125	130	75.5	20	0.85	60	70	77	83	89	102			
E40SM	50	160	144	80	25	1.15	70	77	83	89	102				
E50SM	80	190	158	92.5	25	1.6	77	89	98	102	115				
E60SM	100	250	175	97.5	25	1.9	89	102	115	121					
E70SM	130	321	207	112.5	25	3.1	102	115	121	127	140				
E80SM	150	392	232	122.5	25	3.8	127	153							
E90SM	270	600	303	210-158	30-40	8-7.5	152-229 TO ORDER								

IMPERIAL TABLE	ENGINE POWER RANGE (HP)		DIMENSIONS (INCHES)												
	MODEL	MIN	MAX	A	B	L (MAX)	MASS (LB)	STOCK HOSE ADAPTORS D (OTHER SIZES AVAILABLE ON REQUEST)							
E02M	4	24	2.60	2.56	0.79	0.7	1.0	1.4	1.5	1.6	1.8				
E05M	5	36	3.19	2.56	0.79	1.0	1.4	1.5	1.6	1.8	1.9	2.0	2.4		
E10M	10	60	4.04	3.17	0.79	1.5	1.8	1.9	2.0	2.2	2.3	2.4	2.4	2.5	2.8
E20M	40	105	4.78	3.27	0.79	1.9	1.8	2.0	2.4	2.5	2.8	3.0			
E30SM	54	169	5.12	2.97	0.98	1.87	2.4	2.8	3.0	3.3	3.5	4.0			
E40SM	67	216	5.67	2.79	0.98	2.54	2.8	3.0	3.3	3.5	4.0				
E50SM	107	256	6.22	3.64	0.98	3.5	3.0	3.5	3.9	4.0	4.5				
E60SM	134	337	6.89	3.84	0.98	4.2	3.5	4.0	4.5	4.8					
E70SM	174	433	8.15	4.43	0.98	6.8	4.0	4.5	4.8	5.0	5.5				
E80SM	201	529	9.13	4.82	0.98	8.4	5.0	6.0							
E90SM	362	810	11.93	8.3-6.2	1.2-1.6	17.6-16.5	6-9 TO ORDER								

Adaptor sizes highlighted **XX** will cause intake restriction and should only be used at the bottom end of the specified power range.

Contact Wyndham Page or your Wyndham Page supplier for details.

Data subject to change.

Valve Selection

To enable Wyndham Page to select the most suitable shutdown valve for a given application the following data is required:

- Engine type and model.
- Engine rating and / or application details.
- The internal bore of the intake system hose at the position the valve is to be fitted.
- The cable length for the manual shutdown.
- The option of a lever actuator.

Order Coding

EXXM - XXX - XXX - RXX - X - TXX - SXXX

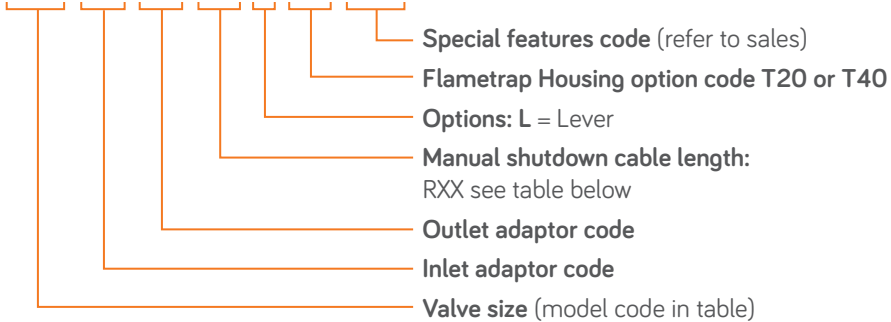

Use metric value for adaptor code, add zero to make 3 digit code e.g. 25 = 025

Combine inlet and outlet adaptor codes if the same.
Special features by arrangement with Wyndham Page.

STANDARD CABLE LENGTHS	
CABLE CODE	LENGTH (M)
05	0.5
10	1.0
15	1.5
20	2.0
25	2.5
30	3.0

Additional Options

Flametrapp Housing Option - Order Code "TXX": A Flametrapp housing, fitted in place of the outlet adaptor is available as an option. It is suitable for a 118mm diameter crimped ribbon type Flametrapp element of depth 20mm (code T20) or 40mm (code T40). The housing has a mounting flange as shown in the drawing below. This option is only available on valve sizes E02 to E40.

Note:

- 1 The Flametrapp element is not included with the valve.
- 2 The Flametrapp Housing does not form part of the ATEX/UKEX valve certification and must be installed and tested on the engine with the Flametrapp element fitted according to applicable standards such as EN-1834.

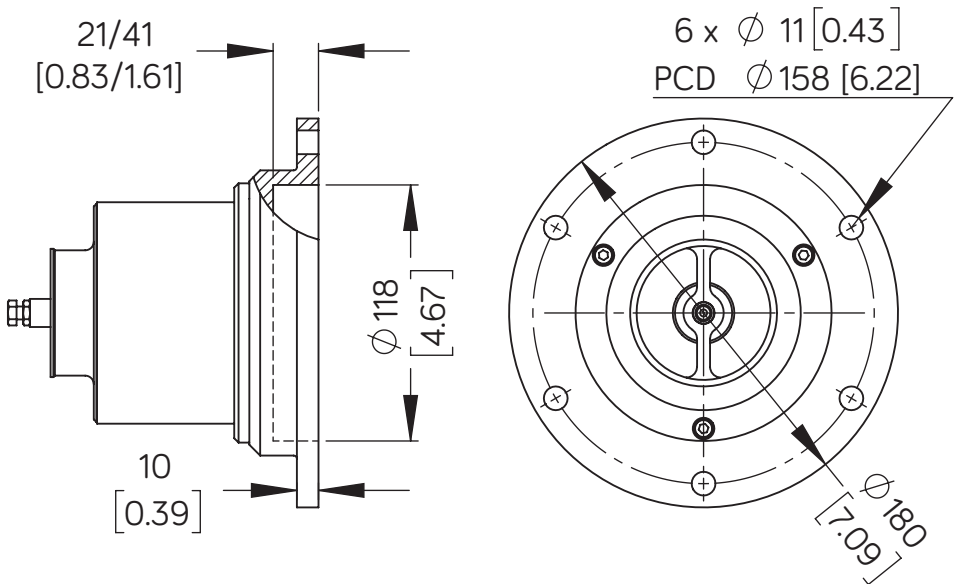

Valve Marking

Valves are marked using labels as shown below with following information

- Serial No
- Part Number
- Year of Manufacture
- CE Mark
- UKCA Mark
- Ex Equipment marking, protection type etc
- Ambient temperature limits
- Max airflow temperature
- Airflow direction arrow
- Instruction notice and handbook QR code link

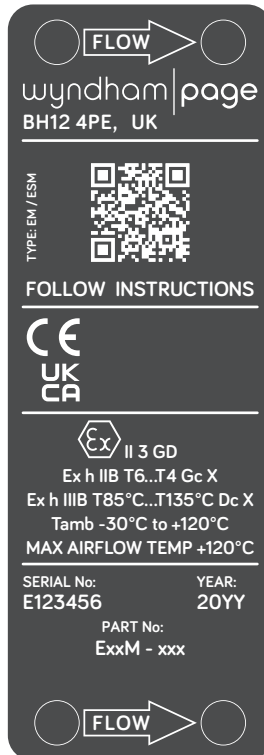

Valve Installation

Wyndham Page E-M valves are supplied complete with the manual shutdown pull handle and the selected length of cable fitted and adjusted. It is recommended that the pull handle and cable are not separated from the valve when installing.

Subject to the comments below generally install the Wyndham Page E-M Series valve as close to the engine intake manifold as practical. The valve may be fitted in any attitude from vertical to horizontal. When planning and checking an installation always ensure that:

- a. Adjustment and locking of the setting screw is possible.
- b. A suitable run for the manual shutdown cable is accommodated.
- c. The direction of airflow is in compliance with the arrow marked on the body of the valve.
- d. An **Air Filter Element** must always be fitted in the engine air intake system **upstream** of the Valve.
- e. **Valve location in the Air Intake System (refer to schematics below)**

Yes ✓ No ✗ See Notes !

In all cases the Valve must be located where both ambient and intake air temperature does not exceed 120°C.

- **Normally Aspirated Engines (no turbocharger):** fit the valve between the engine and the air filter (see schematic below).

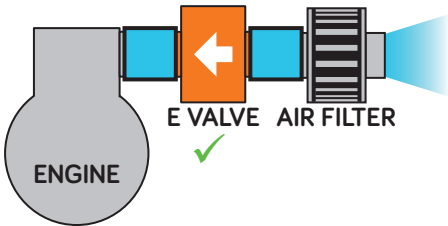

- **Turbocharged Engines:** fit the valve upstream [air filter side] of the turbocharger. **Do not** fit the valve between turbocharger and engine (see schematic below).

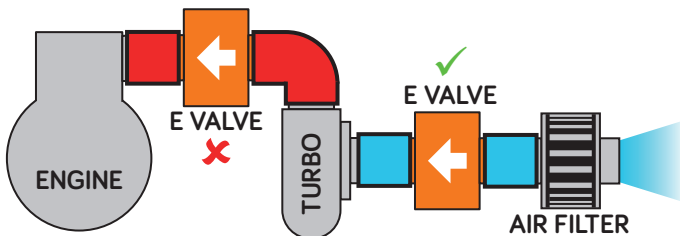

- **Turbocharged Engines with Intercooler:** fit the valve upstream (air filter side) of the turbocharger. If this is not possible the valve may be fitted downstream of the intercooler **only** if the hose adaptor size for the valve is not too restrictive. (!) Note a reduced engine performance may result from this arrangement. If in doubt consult Wyndham Page for further assistance. **Do not** fit the valve between turbocharger and intercooler (see schematic below).

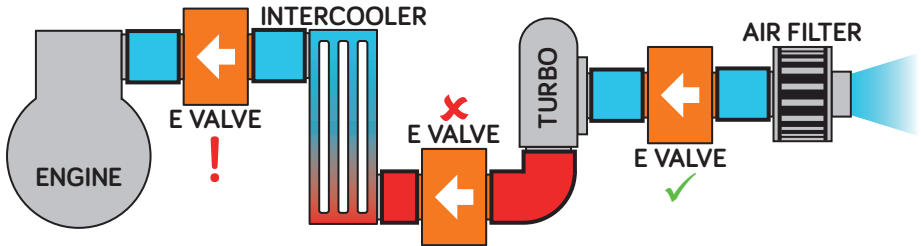

- In all cases where an **Intake Flametrap** is also fitted, the valve must be installed **upstream** of the flametrap.
- The hose into which the valve is fitted should be adequate to fully support the valve whilst not permitting excessive vibration of the valve. For the heavier valves in the range a support bracket for the valve may be necessary. Generally ensure that there is sufficient flexibility in the finalised intake system installation to allow for the relative movement between the system components over the full range of engine operating conditions thereby avoiding excessive mechanical stresses.
- In the case of an engine with **Multiple Intake Systems** requiring the fitting of more than one Wyndham Page E-M valve, a suitable balance pipe must be installed between the intake system pipes downstream [engine side] of the valves to give simultaneous shutdown of the fitted valves. Typically such a balance pipe should be 30% to 40% of the intake pipe diameter.
- Any engine **Crankcase Breather** arrangement venting directly into the intake ports or into the air intake system downstream of the Wyndham Page E-M valve must be sealed and replaced by an external breather system connected to the intake system upstream of the E-M valve or [if permitted at the operating site] vented to atmosphere.

Manual Emergency Stop Installation

A pull “T” handle is supplied as standard for manual emergency valve closure. Valve types E50M to E90M have the option of a lever operated manual shutdown actuator.

Both types are shown below and on page 12. Always install the manual shutdown actuator in a convenient position such that it can be easily accessed during an emergency situation. The “T” handle type can be located in a suitable bulkhead or mounting bracket by providing a 18mm diameter hole. To fit the pull handle assembly release the handle locknut and remove the handle. Remove the body locknut and washer at the handle end and push the handle body through the 18mm hole. Refit body washer and locknut adjusting both body locknuts as required. Refit handle locknut and handle and tighten. In the case of the optional lever type actuator two 7mm diameter holes are provided through the body for fixing.

Note. Towards the upper end of the relevant E-M size range for both types of manual actuator a significant force may be required to operate when the engine is not running. Once the engine is running the force required to carry out a manual emergency stop reduces as the engine speed increases.

Important Note. Always retain the standard fuel stop provided with the engine. The E-M valve manual stop should never be used as the normal way to stop an engine. It is intended for emergency operation only or when checking for correct functioning.

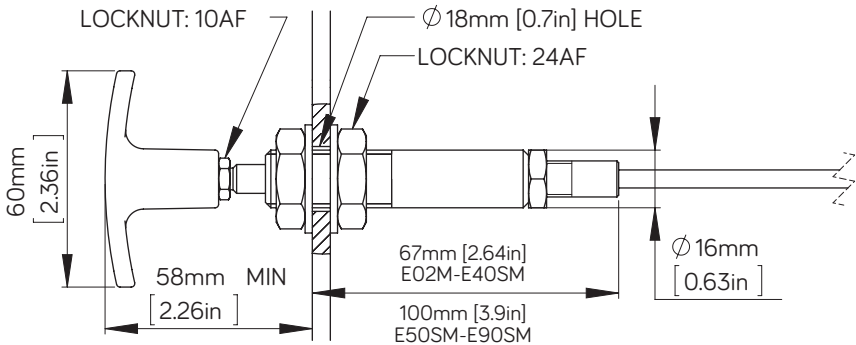

T HANDLE AS STANDARD

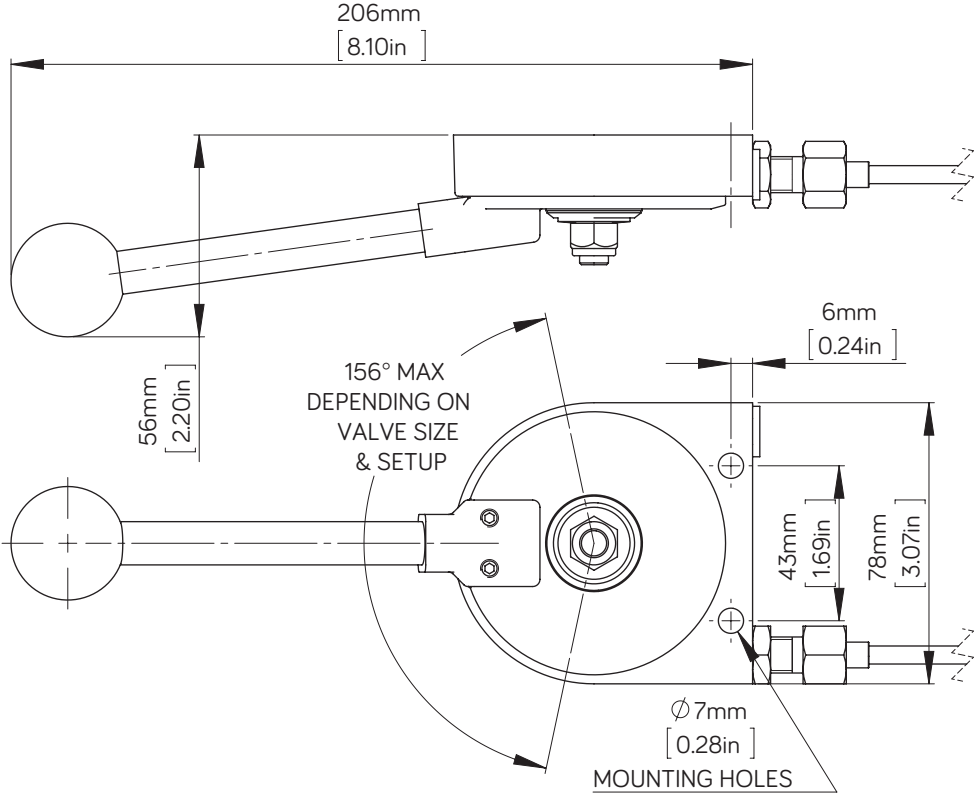

LEVER OPTION FOR VALVES E50SM TO E90SM

Valve Trip Speed Setting

The Wyndham Page E-M valve as supplied will normally be set to trip at a speed below that required. To adjust the trip speed use the trip adjuster screw and associated lock nut. See diagram below.

E02 TO E20M VALVES

TRIP SPEED ADJUSTER SCREW: 10 AF
LOCKNUT: 10 AF
SPANNER FLATS: 13 AF
INLET ADAPTOR

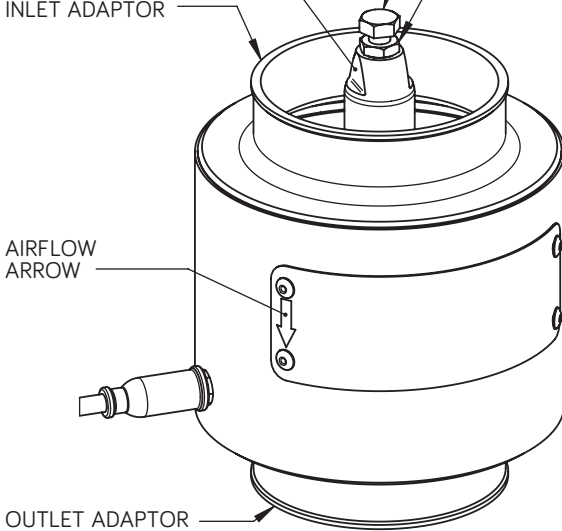

E30SM & E40SM VALVES - 13 AF
E50SM TO E80SM VALVES - 16 AF
E90SM VALVE - 24 AF

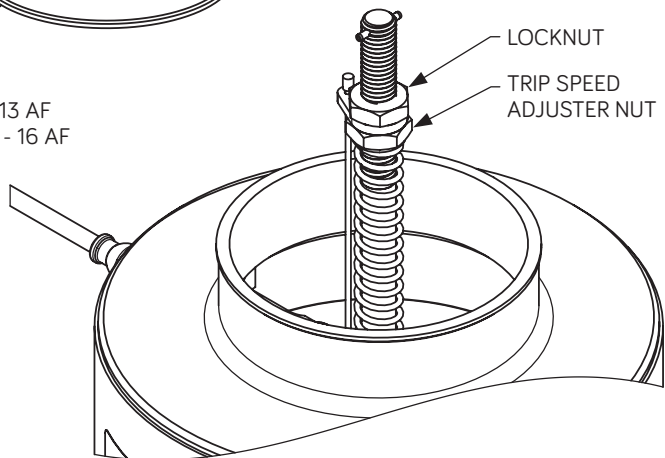

Rotating the adjuster clockwise increases the trip speed. Prior to attempting to set the trip speed check that the manual emergency stop pull handle is in the run condition. To set:

- [1]. Check adjuster locknut is tight and that the intake system from air cleaner to intake manifold is fitted and secured and is leak free.
- [2]. Start engine. Slowly increase speed until a shutdown occurs. [Note; if no shutdown occurs up to the maximum available engine speed with maximum throttle, remove air hose connection from the inlet end of the Wyndham Page valve as necessary to gain access to the adjuster and locknut. Release the adjuster locknut and rotate the adjuster two turns anticlockwise. Tighten locknut, refit hose and recheck for shutdown].
- [3]. Following initial shutdown remove air hose at the inlet end of the shutdown valve as necessary to gain access to the adjuster and locknut.
- [4]. Release locknut and rotate adjuster one turn clockwise.
- [5]. Tighten locknut, refit hose as necessary, start engine and slowly increase speed up to the maximum available.
- [6]. Repeat steps [3], [4] and [5] until the first time that no shutdown occurs up to the highest speed available. Then rotate the adjuster a further one half turn clockwise and tighten the locknut. With the intake system fully fitted and the engine fully warmed up, slowly run up and down the engine speed range a number of times to check no further shutdown occurs. If a further shutdown occurs reset the adjuster one further half turn clockwise and check again until no shutdown occurs.
- [7]. Finally restart engine and run at about half maximum speed [or higher if this not possible]. Operate the manual emergency stop to ensure that the engine stops within a few seconds.

Notes:

In the case of turbocharged engines it is important that the final check above is carried out with the engine under load.

A more precise method to set the trip speed is achieved by monitoring and recording the engine speed during adjustment and by temporarily raising the engine high idle speed [if safe to do so] to enable the final trip setting speed to be measured. Once the trip speed is set, the high idle must be reset to its standard setting.

Maintenance

The following maintenance schedule should be undertaken. Subject to experience of local operating conditions the frequency of the maintenance requirements may need to be varied.

- DAILY: Run engine at mid range speed [or higher if this not possible].
Operate the manual emergency stop. The engine should stop within a few seconds.
- MONTHLY: [1]. Check intake pipework between valve and engine to ensure all pipe fixings and any support brackets are properly fitted and secure and that the engine intake is leak free and shows no signs of significant damage.
- [2]. Check the shutdown trip speed setting is correct by either :
- [a] Carrying out the trip speed adjustment as outlined herein or;
- [b] Temporarily raise the engine high idle and check trip speed using an engine tachometer.
- 3 MONTHLY: [1]. Remove valve complete with manual stop handle and cable.
- [2]. Clean valve as necessary using a soft brush / air line plus white spirit or similar if necessary taking all normal precautions. Dry valve.
- [3]. Check that the valve moves smoothly over its complete operating stroke and that there are no signs of significant damage or excessive wear. Do not lubricate.
- [4]. Check the manual stop handle and cable for damage or wear. Check for freedom of operation.
- [5]. Refit valve and complete “daily and monthly” checks as above.
- NOTES: [a]. Carry out the above maintenance whilst the engine is in a non-hazardous area.
- [b]. Where applicable ensure that the high idle speed of the engine is reset to the correct value.
- [c]. Any problems identified must be rectified before returning the equipment to a hazardous area.

Specification Table

ATEX CERTIFICATION	
The E Series of Wyndham Page automatic overspeed shutdown valves are certified and marked as follows:	
Equipment Marking:	 II 3 GD
	Ex h IIB T6...T4 Gc X
	Ex h IIIB T85°C...T135°C Dc X
	Tamb -30°C to +120°C
Process temperature:	MAX AIRFLOW TEMP: +120°C
Special conditions for safe use:	1. An air filter element shall be fitted in the engine air intake system upstream of the Valve.
Standards used in compliance:	EN 60079-36: 2016 EN 60079-0: 2018
GENERAL SPECIFICATION	
Ambient Temperature:	-30°C to +120°C
Intake Air Temperature:	-30°C to +120°C
Construction:	Aluminium - anodized or powder coated
	Hose Adaptors: Aluminium - anodized

Notes:

Notes:

Notes:

wyndham | page

Unit 1c Chalwyn Industrial Estate, Parkstone, Poole,
Dorset BH12 4PE United Kingdom

Tel: +44 (0)1202 734 656

Email: sales@wyndhampage.com

www.wyndhampage.com