

E03F / E03FM Series

Automatic Engine Overspeed Shut Down Valve and Air Cleaner Assemblies with Manual Shut Down Option

Easily installed range of diesel engine automatic air intake valves with integrated air cleaner & manual shut down option.

ATEX &
UKEX
Certified



wyndham | page

About Wyndham Page Ltd

Based in the UK Wyndham Page specialise in the design and manufacture of safety equipment for diesel engines.

Our product range of Air Intake Shutdown Valves includes our E Series Automatic Valves and our F Series Butterfly Valves with solenoid, pneumatic or manual actuation options. We offer Speedswitch kits for the F Series valves, a range of G Series Mechanical Engine Safety Products and a range of Spark Arresters designed to prevent the emission of high energy sparks from diesel exhaust systems.

Wyndham Page is headed by Freddy Page-Roberts who brings over 20 years' experience in the diesel safety industry and was previously managing director of Chalwyn Ltd.

All members of the senior management team have considerable experience in organisations specialising in the design and manufacture of hazardous area equipment for diesel engines.

Quality Assurance

Wyndham Page Valves are manufactured and tested under our EN ISO 9001: 2015 quality management system.

Wyndham Page Ltd are certified to supply Ex equipment under Quality Assurance Notification CML ATEXQ11003 in the UK, CML ATEXQ13649 in the EU and IECEx Quality Assurance Report GB/CML/QAR17.0023/01.

- Equipment supplied with an UK Declaration of Conformity is CA marked and meets the provision of the UK directive SI 2016No. 1107
- Equipment supplied with an EU Declaration of Conformity is CE marked and meets the provision of the ATEX directive 2014/34/EU.

Engine Breather Kits:

Are available for the Yanmar L48N, L70N and L100N engines. Each kit comprises parts for sealing the existing crankcase breather and venting via the E03F or E03FM valve and for mounting the valve to the engine. Details are available for download on our website. Please contact Wyndham Page or your Wyndham Page supplier for additional details.

Application

The E03F and E03FM Wyndham Page automatic overspeed shutdown valves are designed to be fitted to the air intakes of Diesel engines operating in areas where flammable gas, vapour or dust may enter the atmosphere and are certified for use in Zone 2, gas group IIB and Zone 22, dust group IIIB hazardous areas..

Should such flammable material be drawn into the engine intake this may result in uncontrolled engine overspeed and a situation in which shut down of the normal diesel fuel supply may fail to stop the engine.

Under these circumstances a rapid shut down of the engine is required by immediate closure of the engine air intake thereby reducing the potential for major damage and possible ignition of the flammable material in the surrounding atmosphere.

The E03F and E03FM Wyndham Page automatic engine air intake shut down valve and air cleaner assemblies are suitable for installation on either naturally aspirated or turbocharged engines.

Once installed and set, the repeatability of the actual engine automatic shut down speed has a greater scatter in the case of turbocharged engines than for naturally aspirated types. However, unless there is a special requirement for a very precise shut down speed, adequate protection from excessive engine overspeed is achieved.

Principle of Operation

The actuation force to close the valve is derived from the engine intake air flow passing through the valve. As the air flow increases this actuation force also increases. This force is resisted by an internal valve spring, the pre-load of which is adjusted via the “Trip Adjuster Screw”.

Once the actuation force exceeds the resisting force of the valve spring, the valve rapidly moves to the closed position. Once closed the E03F/E03FM valve remains shut until the engine has fully stopped. The valve then resets to the open position after a delay of some seconds.

Enhanced Protection [Manual Shutdown]

The Wyndham Page E03FM shut down valve kit also includes a pull handle to actuate manual valve closure under emergency situations.

Description & Main Dimensions

An outline arrangement of the E03F / E03FM valve as supplied complete with air cleaner and air cleaner cover is shown below. The principal dimensions are tabulated on page 5.

Note the rubber adaptor which is designed to slide over and clamp onto the intake pipe of the engine. This rubber adaptor is selected in consultation with the customer from the available range sized to suit typical engine intakes in the power band covered by the E03F / E03FM valves [see dimension "A" below and in the tabulated data on page 5].

For E03FM valve types the manual emergency stop actuator is connected to the valve via a mechanical cable. The length of this cable may be selected from the standard stocked range listed on page 6. Alternative cable lengths may be available on application.

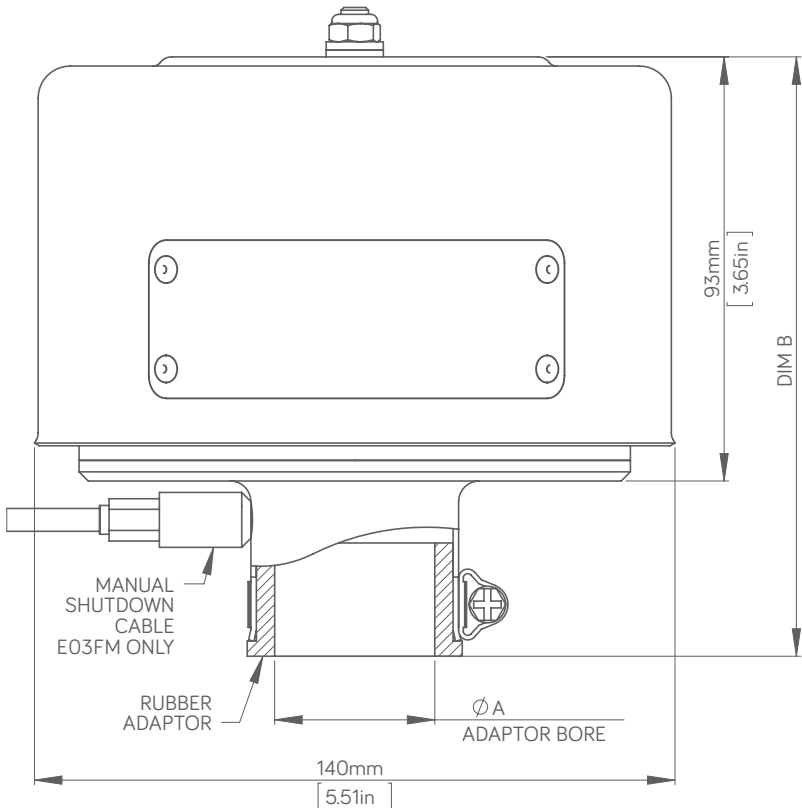

METRIC TABLE	ENGINE POWER RANGE (KW)		DIMENSIONS (MM)			
MODEL	MIN	MAX	A	B (E03F)	B (E03FM)	MASS (KG)
E03F-035	3	20	35	117	131	0.8
E03F-038			38			
E03F-040			40			
E03F-042			42			
E03F-044			44			

IMPERIAL TABLE	ENGINE POWER RANGE (HP)		DIMENSIONS (INCHES)			
MODEL	MIN	MAX	A	B (E03F)	B (E03FM)	MASS (LB)
E03F-035	4	27	1.38	4.59	5.14	1.8
E03F-038			1.50			
E03F-040			1.57			
E03F-042			1.65			
E03F-044			1.73			

Data subject to change

Valve Selection

To enable Wyndham Page to select the most suitable shut down valve for a given application the following data is required:

- Engine type and model.
- Engine rating and / or application details.
- The external diameter of the intake system pipe to which the valve is to be fitted.
- Where applicable the cable length for the manual shut down.

Order Coding

E03F - XXX - SXXX

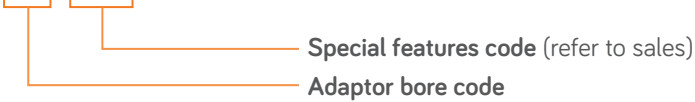

E03FM - XXX - RXX - SXXX

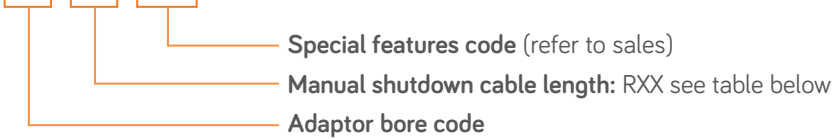

Use metric value for adaptor bore, add zero to make 3 digit code e.g. 35 = 035

Special features by arrangement with Wyndham Page.

STANDARD CABLE LENGTHS	
CABLE CODE	LENGTH (M)
05	0.5
10	1.0
15	1.5
20	2.0
25	2.5
30	3.0

Valve Marking

Valves are marked using labels as shown below with following information

- Serial No
- Part Number
- Year of Manufacture
- CE Mark
- UKCA Mark
- Ex Equipment marking, protection type etc
- Ambient temperature limits
- Max airflow temperature
- Airflow direction arrow
- Instruction notice and handbook QR code link

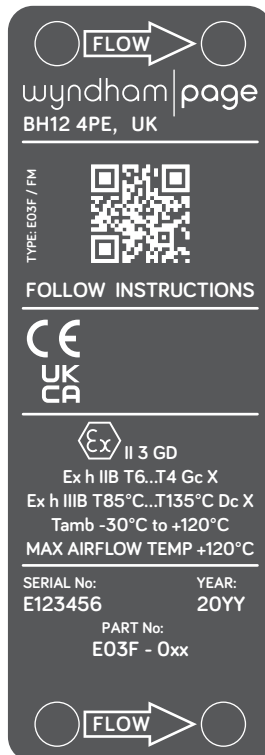

Valve Installation

Subject to the comments below generally install the Wyndham Page E03F Series valve as close to the engine intake manifold as practical. The valve may be fitted in any attitude from vertical to horizontal. When planning and checking an installation always ensure that:

- a. Adjustment and locking of the setting screw is possible.
- b. In all cases the Valve must be located where both ambient and intake air temperature does not exceed 120°C..
- c. An **Air Filter Element** must always be fitted in the engine air intake system **upstream** of the Valve.

The Wyndham Page E03F / E03FM valve / air cleaner assemblies are designed to fit in place of the existing engine air cleaner assembly.

E03FM valves are supplied complete with the manual shut down pull handle and selected length of shut down cable fitted and adjusted. It is recommended that the pull handle and cable are not separated from the valve when installing.

Ideally the E03F / E03FM should be fitted such that the air cleaner cover can be removed to enable element change and valve setting adjustment without the need to detach the complete E03F assembly from the engine. The valve assembly may be fitted vertically [with the air cleaner cover uppermost] through to horizontally. Also in the case of the E03FM ensure that when fitted a suitable run for the shut down cable is accommodated.

The pipe and associated hoses onto which the valve is fitted should be adequate to fully support the valve whilst not permitting excessive vibration of the valve. Consider support brackets if necessary. Generally ensure that there is sufficient flexibility in the finalised intake system installation to allow for the relative movement between the system components over the full range of engine operating conditions thereby avoiding excessive mechanical stresses.

Any engine crankcase breather arrangement venting directly into the intake ports or into the air intake system downstream of the Wyndham Page E03F valve must be sealed and replaced by an external breather system vented to atmosphere.

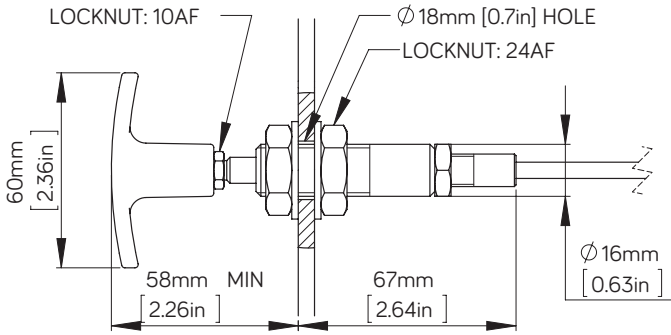

T HANDLE FOR E03FM VALVE

In the case of E03FM valves fit the pull handle for the manual emergency stop in a convenient position such that it can be easily accessed during an emergency situation. With reference to the diagram above the pull handle assembly may be located in a suitable bulkhead or mounting bracket by providing an 18mm diameter through hole. To fit the pull handle assembly release the handle locknut and remove the handle. Remove the body upper locknut and washer and push the handle body through the hole provided in the bulkhead / bracket. Refit the upper locknut and washer. Adjust / tighten upper and lower locknuts as required. Refit handle locknut and handle and tighten.

Important Note. Always retain the standard fuel stop provided with the engine. The E03FM valve manual stop should never be used as the normal way to stop the engine. It is intended for emergency operation only or when checking its correct functioning.



Valve Trip Speed Setting

The Wyndham Page E03F and E03FM valves as supplied will normally be set to trip at a speed below that required. To adjust the trip speed use the trip adjuster screw and associated lock nut. See diagram below.

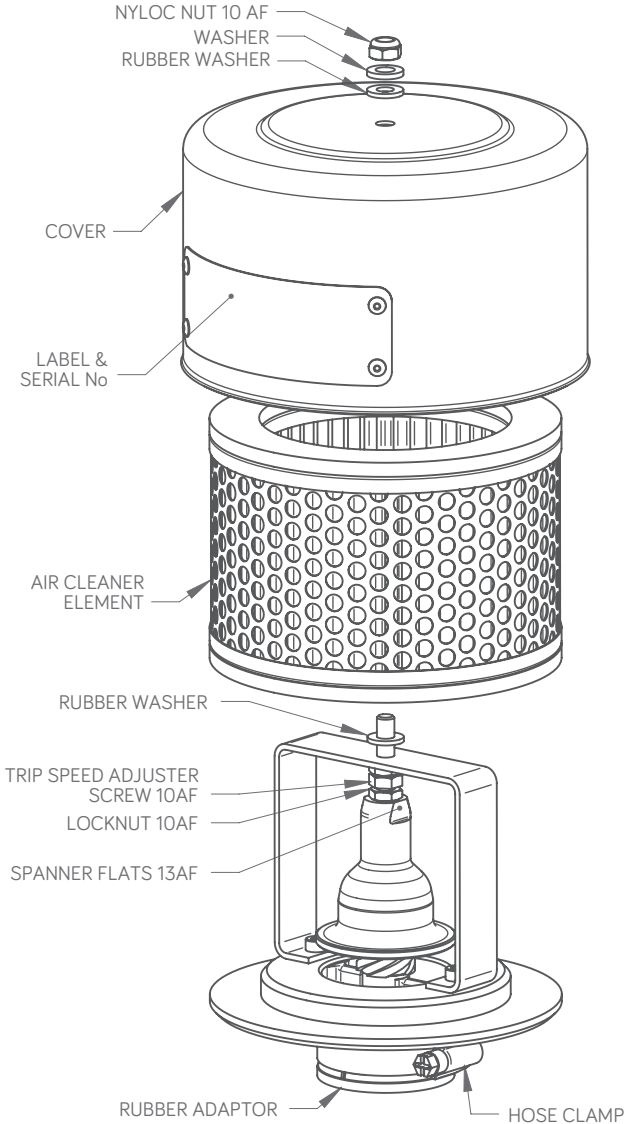

VIEW WITH AIR CLEANER & COVER REMOVED

Rotating the adjuster screw clockwise increases the trip speed. Prior to attempting to set the trip speed check that where applicable the manual emergency stop pull handle is in the run condition i.e. fully pushed in. To set:

- [1]. Check adjuster screw locknut is tight and that the intake system from valve assembly [including air cleaner element and cover], to intake manifold is fitted and secured and is leak free.
- [2]. Start engine. Slowly increase speed until a shut down occurs. [Note; if no shut down occurs up to the maximum available engine speed with maximum throttle, remove air cleaner cover and cleaner element from the Wyndham Page valve assembly to gain access to the setting screw and locknut. Release setting screw locknut and rotate the setting screw two turns anticlockwise. Tighten locknut, refit air cleaner and cover and recheck for shutdown].
- [3]. Following initial shut down remove air cleaner cover and cleaner element to gain access to the setting screw and lock nut.
- [4]. Release setting screw locknut and rotate setting screw one turn clockwise.
- [5]. Tighten locknut, refit air cleaner and cover, start engine and slowly increase speed up to the maximum available.
- [6]. Repeat steps [3], [4] and [5] until the first time that no shut down occurs up to the highest speed available. Then adjust the setting screw a further one half turn clockwise and tighten the locknut. With the intake system fully fitted and the engine fully warmed up slowly run up and down the engine speed range a number of times to check no further shut down occurs. If a further shut down occurs reset the adjuster screw one further half turn clockwise and check again until no shut down occurs.
- [7]. Finally in the case of E03FM valves restart the engine and run at about half maximum speed [or higher if this not possible]. Operate the manual emergency stop pull to ensure engine stops within a few seconds.

Notes:

In the case of turbocharged engines it is important that the final check above is carried out with the engine under load.

A more precise method to set the trip speed is achieved by monitoring and recording the engine speed during adjustment and by temporarily raising the engine high idle speed [if safe to do so] to enable the final trip setting speed to be measured. Once the trip speed is set, the high idle must be reset to its standard setting.

Maintenance

The following maintenance schedule should be undertaken for all E03F and E03FM valves except where stated otherwise. Subject to experience of local operating conditions the frequency of the maintenance requirements may need to be varied.

- DAILY: [E03FM valves only.] Run engine at mid range speed [or higher if this not possible]. Operate the emergency pull stop. The engine should stop within a few seconds.
- MONTHLY:
- [1]. Check intake pipework between the Wyndham Page valve and engine to ensure all pipe fixings and any support brackets are properly fitted and secure and that the engine intake is leak free and shows no signs of significant damage.
 - [2]. Check the shut down trip speed setting is correct by either:
 - [a] Carrying out the trip speed adjustment as outlined herein or;
 - [b] Temporarily raise the engine high idle and check trip speed using an engine tachometer.
- 3 MONTHLY:
- [1]. Remove valve and air cleaner assembly and, where applicable, the manual emergency pull stop and cable.
 - [2]. Clean valve [not air cleaner element] as necessary using a soft brush/air line plus white spirit or similar if necessary taking all normal precautions. Dry valve.
 - [3]. Check that the valve moves smoothly over its complete operating stroke and that there are no signs of significant damage or excessive wear. Do not lubricate.
 - [4]. Where fitted check the manual pull stop and cable for damage and wear. Check it operates freely.
 - [5]. Refit valve and complete “monthly” checks as above plus daily check where applicable.

- NOTES:
- [a]. Carry out the above maintenance whilst the engine is in a non-hazardous area.
 - [b]. Where applicable ensure that the high idle speed of the engine is reset to the correct value.
 - [c]. Any problems identified must be rectified before returning the equipment to a hazardous area.
 - [d]. Air cleaner elements should be serviced in accordance with the engine manufacturers instructions.

Specification Table

ATEX CERTIFICATION	
The E03F Series of Wyndham Page automatic overspeed shutdown valves are certified and marked as follows:	
Equipment Marking:	Ⓔ II 3 GD
	Ex h IIB T6...T4 Gc X
	Ex h IIIB T85°C...T135°C Dc X
	Tamb -30°C to +120°C
Process temperature:	MAX AIRFLOW TEMP: +120°C
Special conditions for safe use:	1. An air filter element shall be fitted in the engine air intake system upstream of the Valve.
Standards used in compliance:	EN 60079-36: 2016 EN 60079-0: 2018
GENERAL SPECIFICATION	
Ambient Temperature:	-30°C to +120°C
Intake Air Temperature:	-30°C to +120°C
Construction:	Body and main internal parts: Aluminium and Steel
	Filter Cover: Steel - powder coated

Notes:

wyndham | page

Unit 1c Chalwyn Industrial Estate, Parkstone, Poole,
Dorset BH12 4PE United Kingdom

Tel: +44 (0)1202 734 656

Email: sales@wyndhampage.com

www.wyndhampage.com